

# CV-305

When it comes to welding mild steel, stainless steel, aluminum and alloy materials, you won't find a more reliable power source than the CV-305. This well-engineered CV unit features two inductance connections. Lincoln's Twist-Mate® output connectors make it easy to choose the right inductance for your application.

This unit is the most compact unit in its class, yet it's loaded with convenient features! Digital meters that can be preset, line voltage compensation, a remote *and* local control option, and a 7-year rectifier warranty — what more do you need?



Output



Input



## Processes

MIG Flux-Cored

## Advantage Lincoln

### • Precision Arc Performance

- Stack them three-high or purchase an affordable package that includes the new LF-72 feeder, a Magnum® 400 MIG gun and more!
- Two output connectors allow you to optimally connect to high or low inductance for arc control. Use low inductance output connection when short-arc welding, and high inductance output connection with spray and globular transfer welding

### • Features & Innovations

- Compact unit is 20 lbs. (9.0 kg) lighter and significantly smaller than competitive models — save your space!
- Easy access Twist-Mate® connection on the front of the machine.
- Digital Ammeter/Voltmeter read-out display allows presets for added convenience and accuracy.

### • Quality & Reliability

- Environmentally protected transformer and power rectifier are rugged and reliable.
- Provides line voltage compensation for maintaining weld consistency, even with changes of  $\pm 10\%$ .
- Three-year warranty on parts and labor; seven-year warranty on power rectifier.

## TECHNICAL SPECIFICATIONS

Product Name	Product Number	Input Power	Rated Output Current/Voltage/Duty Cycle	Input Current @ Rated Output	Output Range	Dimensions H x W x D inches (mm)	Net Weight lbs.(kg)
CV-305	K2400-1	208/230/460/3/60	315/32.6V/100%	51/48/24A	50-400A	24.6 x 19.5 x 27.0 (625 x 495 x 686)	330 (149)
	K2400-2	230/460/575/3/60	315/32.6V/100%	48/24/20A			

## A CLOSER LOOK

### FEATURES

- Low flat-top case can be placed under a workbench or stacked on top of each other for smaller footprint.
- 115V or 42VAC wire feeder auxiliary power.
- Twist-Mate® output connectors require no tools for quick and easy hook-up. Two Twist-Mate® Cable Plugs included (K852-95).

### Key Controls

1. Positive Twist-Mate® output connector
2. Low inductance negative Twist-Mate® output connector
3. High inductance negative Twist-Mate® output connector
4. Voltmeter polarity switch
5. 14-pin MS-type wire feeder connector
6. Circuit breakers
7. "On/Off" power switch
8. Thermal trip indicator light
9. Digital Ammeter/Voltmeter display with switch
10. Output control knob
11. Remote/Local control switch

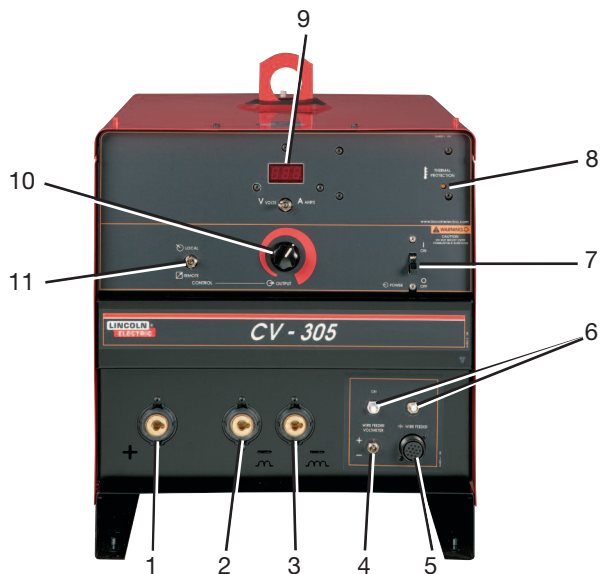

### SYSTEM SELECTION

#### Ready-Pak® Package

Take the hassle out of ordering — order a Ready-Pak® pre-assembled welding package. Fully assembled and ready to weld — just add wire and gas. Select a Ready-Pak® and use one order number on your order form.

#### CV-305 / LF-72 Wire Feeder Ready-Pak® Package Our most popular MIG and flux-cored welding system!

##### Order K2395-1

- CV-305 Power Source (208/230/460/3/60)
- LF-72 Bench Model (Two Roll) Wire Feeder with Universal Wire Reel stand, 10 ft. Control Cable, and .035-.052" solid wire Drive Roll and Guide Tube Kits.
- Magnum 400 Welding Gun, 15 ft., .035-.045" wire
- Work (15 ft.) and Wire Feeder (10 ft.) Power Cables Package
- Harris Flowmeter Regulator and Gas Hose.

(Order Swivel Kit K2332-1 for even more flexibility! Note: Can't be used at the same time with undercarriage while gas cylinder(s) are installed.)



Shown:  
CV-305 / LF-72 Wire Feeder Ready-Pak® Package

**QUALITY AND RELIABILITY**

- Electronic and thermostatic protection from current overload or excessive temperatures.
- “Cold” electrode with a solid state contactor when the trigger is released for added safety.
- Microprocessor-based control PC board has built-in diagnostic routines for quick and easy troubleshooting.
- Circuit boards are protected with a specially insulated coating to extend life and ensure reliable performance.
- Solid state circuitry provides extra long life during repetitive applications.
- Three-year warranty on parts and labor; seven-year warranty on power rectifier.
- Manufactured under a quality system certified to ISO 9001 standards.

**RECOMMENDED OPTIONS**

**GENERAL OPTIONS**



**Remote Output Control**  
 For remote output of welding voltage. Consists of control box with 25 or 100 ft. (7.6 or 30 m) of four conductor cable and 6 pin MS-type connector.  
**Order K857** for 25 ft. (7.6m).  
**Order K857-1** for 100 ft. (30m).



**Jumper Plug Kit**  
 Required to close the contactor in the power source when the power source is used with a remote output contactor such as the contactor in the K449 LN-25, or K1870-1 LN-15 wire feeder.  
**Order K484**



**Remote Control Cable Adapter**  
 Y connection adapter for connecting K857 Remote Output Control (6 pin plug connection) and wire feeder input cable (14 pin plug connection) to power source 14 pin receptacle.  
**Order K864**



**Undercarriage**  
 Platform undercarriage with mounting for two gas cylinders at rear of welder.  
**Order K874**



**Twist-Mate® Cable Plug**  
 For connecting welding cable to output terminal receptacles. For 1/0 – 2/0 (50 – 70 mm<sup>2</sup>) cable.  
**Order K852-70**



**Universal Adapter Plug**  
 The adapter plug allows user connection of any suitable accessory or wire feeder to the output contactor and auxiliary power circuitry. Consists of a 14 pin MS-type (Amphenol) connector with 8” (203mm) stripped leads.  
**Order K867**



**Twist-Mate® Cable Plug**  
 For connecting welding cable to output terminal receptacles. For 2/0 – 3/0 (70 – 95 mm<sup>2</sup>) cable.  
**Order K852-95**

**CV-305 ORDER FORM**

PRODUCT DESCRIPTION	ORDER NUMBER	QUANTITY	PRICE
CV-305 208/230/460/3/60	K2400-1		
CV-305 230/460/575/3/60	K2400-2		
<b>READY-PAK® PACKAGE</b>			
CV-305/LF-72 Bench Model Wire Feeder (208/230/460/3/60)	K2395-1		
<b>RECOMMENDED GENERAL OPTIONS</b>			
Remote Output Control, 25 ft. (7.6m)	K857		
100 ft. (30m)	K857-1		
Remote Control Cable Adapter	K864		
Twist-Mate Cable Plug for 1/0-2/0 (50-70 mm <sup>2</sup> ) cable	K852-70		
Twist-Mate Cable Plug for 2/0-3/0 (70-95 mm <sup>2</sup> ) cable	K852-95		
Jumper Plug Kit	K484		
Universal Adapter Plug	K867		
Undercarriage	K874		
<b>RECOMMENDED WIRE FEEDER OPTIONS</b>			
LF-72 and LF-74	See publication E8.11		
LN-15	See publication E8.60		
LN-23P	See publication E8.90		
LN-25	See publication E8.100		
Cobramatic®	See publication E8.300		
Magnum® Spool Gun	See publication E12.100		
<b>TOTAL:</b>			

**CUSTOMER ASSISTANCE POLICY**

The business of The Lincoln Electric Company is manufacturing and selling high quality welding equipment, consumables, and cutting equipment. Our challenge is to meet the needs of our customers and to exceed their expectations. On occasion, purchasers may ask Lincoln Electric for advice or information about their use of our products. We respond to our customers based on the best information in our possession at that time. Lincoln Electric is not in a position to warrant or guarantee such advice, and assumes no liability, with respect to such information or advice. We expressly disclaim any warranty of any kind, including any warranty of fitness for any customer's particular purpose, with respect to such information or advice. As a matter of practical consideration, we also cannot assume any responsibility for updating or correcting any such information or advice once it has been given, nor does the provision of information or advice create, expand or alter any warranty with respect to the sale of our products.

Lincoln Electric is a responsible manufacturer, but the selection and use of specific products sold by Lincoln Electric is solely within the control of, and remains the sole responsibility of the customer. Many variables beyond the control of Lincoln Electric affect the results obtained in applying these types of fabrication methods and service requirements.

Subject to Change — This information is accurate to the best of our knowledge at the time of printing. Please refer to [www.lincolnelectric.com](http://www.lincolnelectric.com) for any updated information.



**THE LINCOLN ELECTRIC COMPANY**

22801 St. Clair Ave., Cleveland, OH 44117-1199 • 216.481.8100 • [www.lincolnelectric.com](http://www.lincolnelectric.com)