

Product Information

Side Beam Tracks & Travel Carriages

- **Microprocessor Control**
- **Large Variety**
- **For all Welding Processes**
- **Large Weight Capacities**
- **Precision Tracking**
- **Unlimited Lengths**

Introduction

The Jetline range of side beam tracks and carriages is the most comprehensive and versatile range currently available from any manufacturer. Based upon Jetline's 40 years of mechanized welding experience, the range of tracks and carriages has been refined to provide answers to all the requirements for this type of product. Whether the need is for precision, compact design or weight carrying capacity, a model exists for your purposes.

The chart below gives a summary of the range.

Side beam tracks and carriage systems are used in a variety of applications. They consist of three elements - track, carriage and support posts

Track

The track consists of a beam on which the carriage is supported and provides the rails or ways that the carriage rides upon. The track may be left in its natural condition or can be hardened and can be un-machined or machined, depending upon its application. A single track can support a number of carriages and can therefore be used as a positioning support to locate the carriages over the required areas on the part to be welded. It can also be used to provide linear movement of the carriage to complete a longitudinal weld or to provide convenient relocation of the carriage.

Carriage

Carriages can carry one or more welding heads and can be fitted with cantilevered booms, especially on the larger capacity models. They are available as non-powered or powered models, the powered models have a variety of drive systems available for both standard and precision movement. All powered carriages are provided with Jetline's unique 9627 microprocessor control. This unit is operator-friendly and designed to control both the welding sequence and travel speed.

Support Posts

The posts are designed to hold the track at the appropriate height for the application. Multiple posts are used for long tracks and have track adjusting brackets to create and maintain the track alignment over its complete length.

COMPLETE SUMMARY OF JETLINE TRACKS AND CARRIAGES								
Model	Weight Capacity lbs (kg)	Maximum Length Inches (mm)	Track Type	Machined	Hardened	Tracking Accuracy Per 10ft (3m)	Speed Accuracy (Std)	Drive Type
TKB	50 (22)	48 (1220)	Veeway	Yes	Yes	0.015 (0.4)	±2%	Linear Bearing
TKSA	300 (135)	300 (7620)	Roundway	Yes	Yes	0.015 (0.4)	±2%	Rack & Pinion
TKPA	300 (135)	300 (7620)	Roundway	Yes	Yes	0.005 (0.1)	±2%	Rack & Pinion
TKXA	300 (135)	120 (3050)	Roundway	Yes	Yes	0.005 (0.1)	±0.1%	Linear Bearing
TKL-U	300 (135)	300 (7620)	Flatway	No	No	0.060 (1.5)	±2%	Rack & Pinion
TKM-U	500 (225)	300 (7620)	Flatway	No	No	0.060 (1.5)	±2%	Rack & Pinion
TKM-M	500 (225)	300 (7620)	Flatway	Yes	No	0.015 (0.4)	±2%	Rack & Pinion
TKMV	1,000 (450)	No limit	Veeway	Yes	Yes	0.015 (0.4)	±2%	Rack & Pinion
TKHV	1,500 (680)	No limit	Veeway	Yes	Yes	0.015 (0.4)	±2%	Rack & Pinion

Note: Speedholding accuracy of any carriage can be improved to ±1% of the rated speed by the addition of a tach-generator to the motor or to ±0.1% of the rated speed by the use of a precision motor and control.

TKB BENCH STYLE

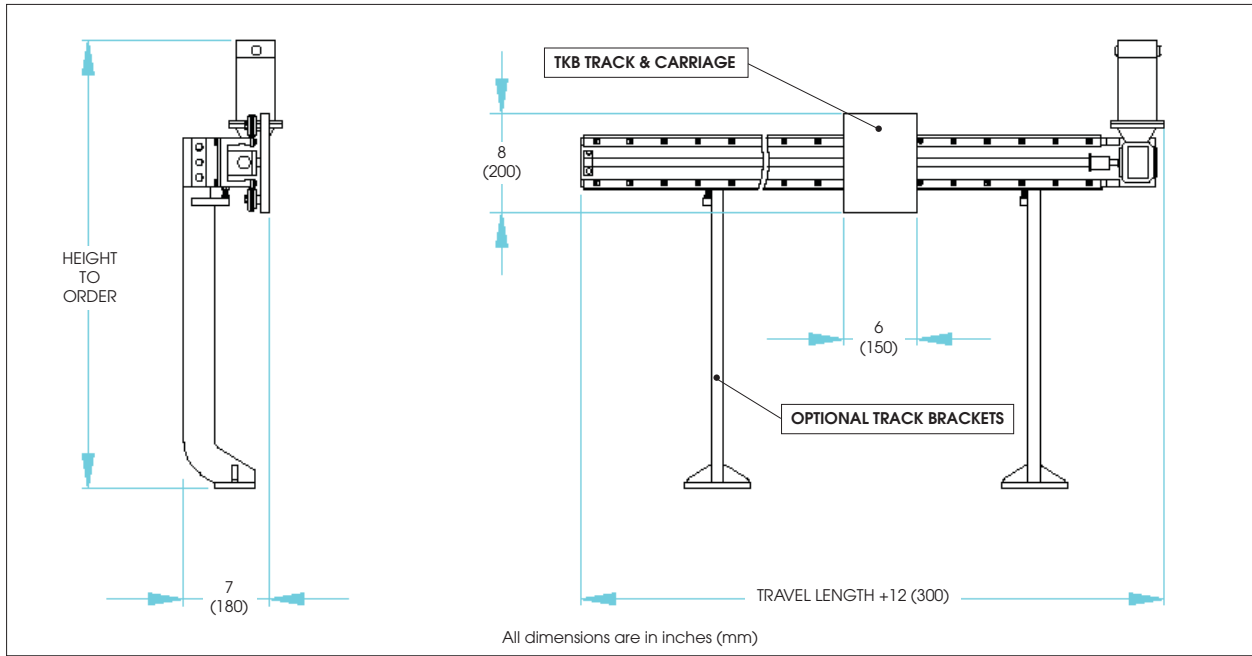

Track

The **TKB** style track is designed for light applications and is suitable for precision welding applications. It consists of an aluminum extrusion fitted with hardened vee-way rails on which the carriage rides. A geared motor, mounted at the end of the track, powers a hardened and ground shaft which engages a linear bearing mounted on the carriage. Travel is smooth and backlash-free. The track and carriage is supplied as a complete unit and cannot be separated.

Although it can be used for all welding applications, the system is suitable primarily for GTAW (TIG) and Plasma welding. The construction of the track and carriage system makes it suitable to carry both the welding torch and arc length control actuator.

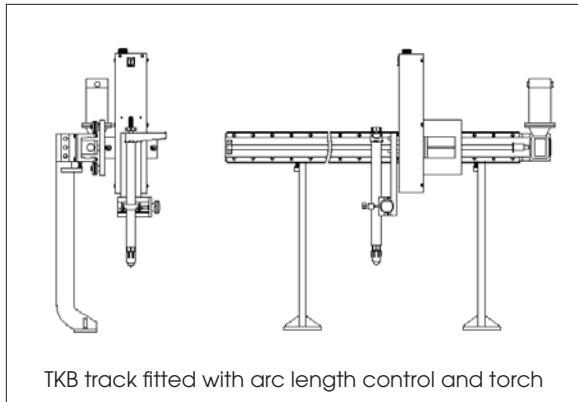

Track Brackets

These are optionally available to support the track and are provided with track adjustment brackets at their upper end to correctly align the track. Two track brackets are used on all track lengths. The track brackets are manufactured to order to suit the application.

Carriages

The TKB carriage has a mounting face for the welding equipment which is 8" x 6" (200 x 150 mm). The carriage is available as a non-powered or powered version. Powered versions are available with various speed ranges and speed holding accuracies. All TKB tracks are linear drive for precision. The full range of available speed ranges is shown in the chart below. Load carrying capacity is 50 lb (22 kg) out 6" (150 mm) from the carriage face.

The carriage rides on the hardened vee-way rails using hardened vee-way wheels with adjustment facilities.

Powered carriages are driven by a DC servomotor controlled by Jetline's unique 9627 microprocessor control. This control sets and maintains the carriage travel speed and can also be interfaced with a suitable welding power supply and with other Jetline microprocessor controls to provide complete sequence control of the weld process. The input voltage is 110/230VAC, 50/60 Hz. The 9627 control is supplied as a separate item with a 10 ft (3 m) interconnection cable to the drive motor.

Adding a tach-generator to the drive motor improves the speed holding accuracy of the system to better than $\pm 1\%$ of the rated speed.

Model	Speed Range		Accuracy
	IPM	mm/min	
TKB-xxC-NP	Non-Powered		
TKB-xxC-A	1.2 - 35	30 - 900	2%
TKB-xxC-B	1.5 - 44	40 - 1120	2%
TKB-xxC-C	2 - 58	50 - 1475	2%
TKB-xxC-D	3 - 88	75 - 2235	2%
TKB-xxC-E	4 - 117	100 - 2975	2%
TKB-xxC-F	6 - 175	150 - 4450	2%

TKSA/PA/XA ROUNDWAY STYLE

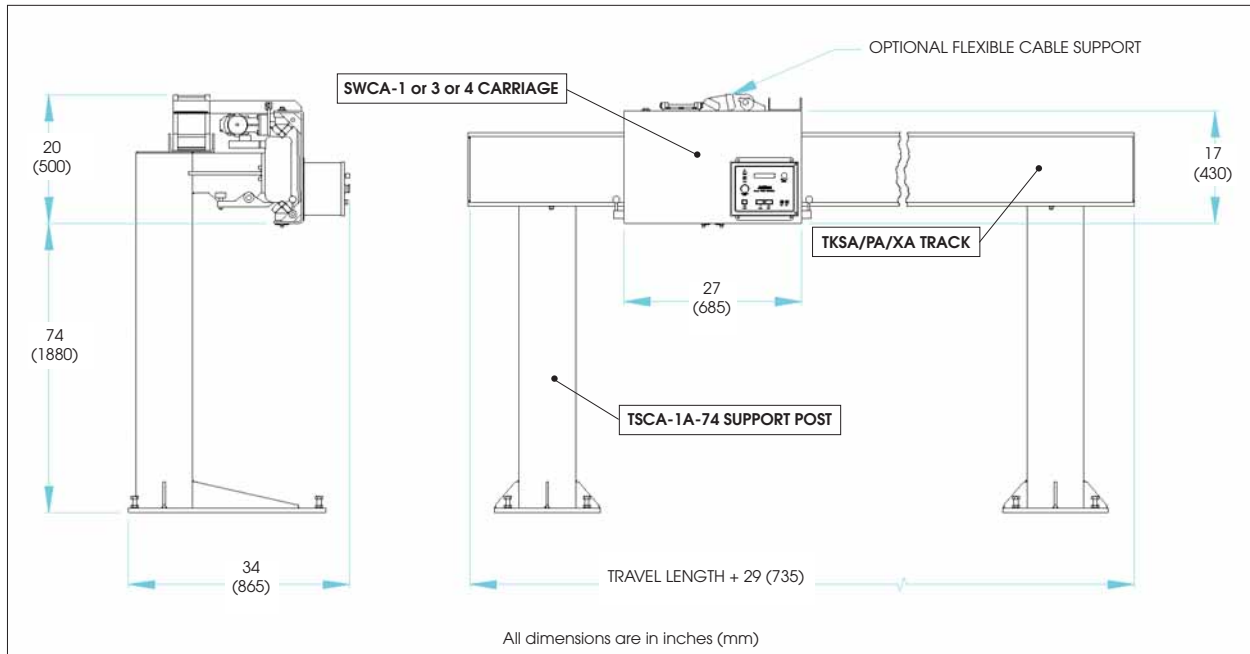

Track

The **TKSA** style track is manufactured from heavy wall rectangular section tube and includes hardened and ground roundways on which the carriage travels. The roundways are located in machined vees and a gear rack is mounted on a machined portion of the track. All the machining operations are carried out at the same time thus providing superior tracking accuracy.

Two other versions of the TKSA track are available, they are designed for precision applications.

The **TKPA** style track has all the features of the TKSA but additional care is taken in its manufacture to provide greater accuracy. This care includes thermal stress relieving of the track prior to machining and the use of special machining techniques. This results in a track which has a guaranteed straightness of $\pm 0.005"$ (0.1 mm) per 10 ft (3 m) length of track. The track has a gear rack for carriage drive.

The **TKXA** track is manufactured with the same care as the TKPA but uses a linear bearing drive system instead of the gear rack. The linear drive is virtually frictionless and is backlash-free.

Support Posts

These are available to support the track and are provided with track adjustment brackets at their upper end to correctly align the track. Two support posts are used on tracks up to 16 ft (4.8 m) long, three posts are used over this length. The posts have floor pads with mounting holes and leveling bolts. Special height posts and posts with powered elevation for the track are available to order.

Carriages

All carriages which are used with the TKSA/PA/XA style tracks are formed construction with a large mounting face for the welding head. They are available as non-powered and powered versions.

Powered versions are available with various speed ranges and speed holding accuracies. SWCB-3AB carriages are rack and pinion drive, SWCA-4A carriages are linear drive for use with the TKXA track. The full range is shown in the chart below. Load carrying capacity is 300 lb (135 kg) out 12" (300 mm) from the carriage face.

The carriage rides on the hardened roundways using hardened cluster bearings which are sealed for life and which guarantee smooth travel.

Powered carriages are driven by a DC servomotor controlled by Jetline's unique 9627 microprocessor control. This control sets and maintains the carriage travel speed and can also be interfaced with a suitable welding power supply and with other Jetline micro-processor controls to provide complete sequence control of the weld process. The input voltage is 110/230VAC, 50/60 Hz.

Adding a tach-generator to the drive motor improves the speed holding accuracy of standard carriages to better than $\pm 1\%$ of the rated speed.

Model	Speed Range		Accuracy
	IPM	mm/min	
SWCA-1	Non-Powered		
SWCB-3AB	2 - 100	50 - 2540	2%
SWCB-3C-2.5	0.05 - 2.5	1.3 - 63	2%
SWCB-3C-5	0.1 - 5	2.5 - 125	2%
SWCB-3C-10	0.2 - 10	5 - 250	2%
SWCB-3C-20	0.4 - 20	10 - 500	2%
SWCB-3D	0.2 - 188	5 - 4775	0.1%
SWC-4A	4 - 170	10 - 4320	2%
SWC-4B	2 - 85	50 - 2150	2%
SWC-4C	0.3 - 160	8 - 4050	0.1%
SWC-4D	0.2 - 106	5 - 2700	0.1%

TKL FLATWAY STYLE

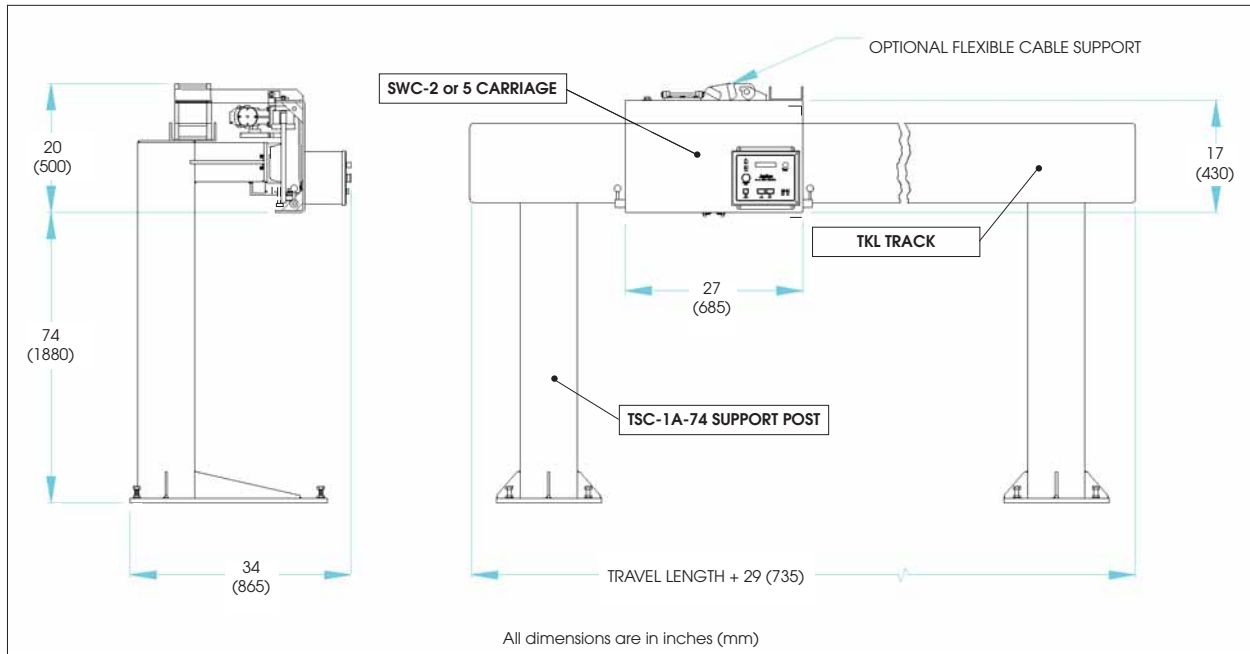

Track

The **TKL** style track is fabricated from flat plate which is reinforced using a structural channel section to which it is welded. The carriage travels on the outer edges of the track which are not hardened. This style of track is available in two versions, either un-machined or machined.

The **TKL-U** un-machined version of the track is ideally suited for applications where it is desired to position and reposition the welding head for various operations. The repositioning can be done with either a manual or a powered carriage. Because the track is un-machined, there is a wide tolerance on the tracking accuracy.

Support Posts

These are available to support the track and are provided with track adjustment brackets at their upper end to correctly align the track. Two support posts are used on tracks up to 12 ft (3.6 m) long, three posts are used over this length. The posts have floor pads with mounting holes and leveling bolts. Special height posts are available to order.

Carriages

The carriage used with the TKL style track is of formed construction with a large mounting face for the welding head. The carriage is available as a non-powered or a powered version. Powered versions are available with various speed ranges and speed holding accuracies and are rack and pinion driven. The full range is shown in the chart below. Load carrying capacity is 300 lb (135 kg) out 12" (300 mm) from the carriage face when used with the un-machined TKL-U track.

The carriage rides on the track using hardened cam followers which are sealed for life and which provide smooth travel.

Powered carriages are driven by a DC servomotor controlled by Jetline's unique 9627 microprocessor control. This control sets and maintains the carriage travel speed and can also be interfaced with a suitable welding power supply and with other Jetline microprocessor controls to provide complete sequence control of the weld process. The input voltage is 110/230VAC, 50/60 Hz.

Adding a tach-generator to the motor improves the speed holding accuracy of the standard carriages to better than $\pm 1\%$ of the rated speed.

Model	Speed Range		Accuracy
	IPM	mm/min	
SWC-2	Non-Powered		
SWCB-5A	3 - 135	75 - 3425	2%
SWCB-5B	1.5 - 75	40 - 1900	2%
SWCB-5C-3	0.06 - 3	1.5 - 75	2%
SWCB-5C-5	0.1 - 5	2.5 - 125	2%
SWCB-5C-10	0.2 - 10	5 - 250	2%
SWCB-5C-20	0.4 - 20	10 - 500	2%

TKM BOX SECTION STYLE

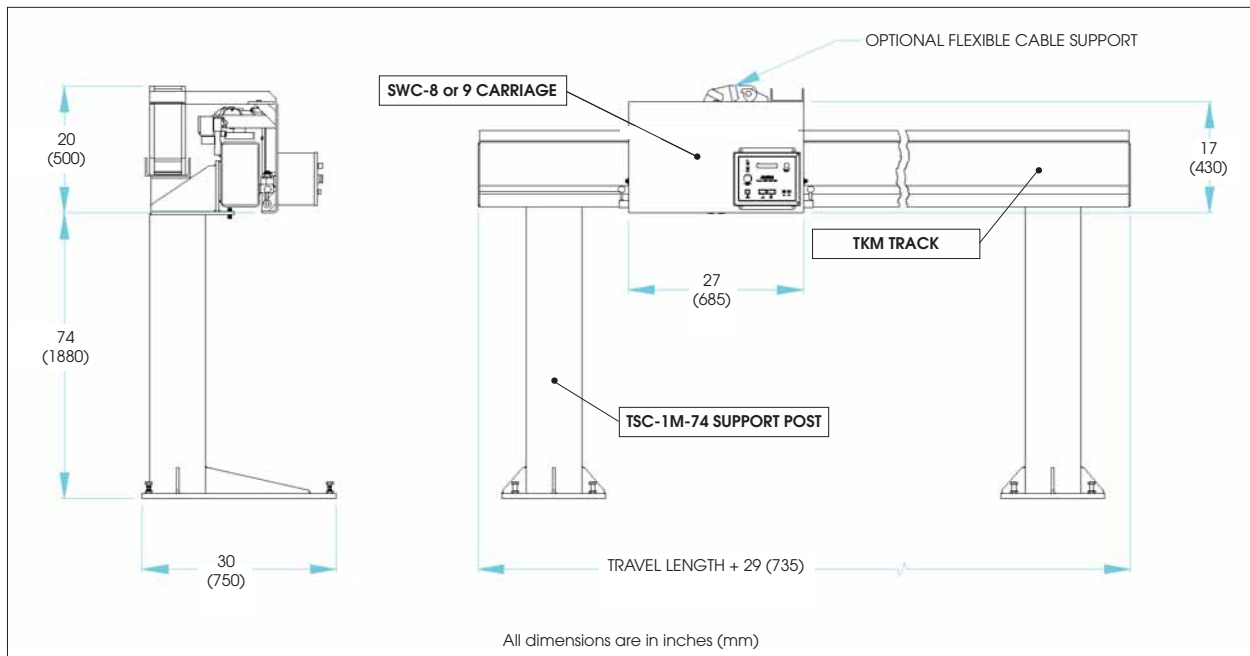

Track

The **TKM** style track is designed primarily for on-site manufacture. To avoid the costs associated with the international shipment of large steel fabrications, Jetline will supply manufacturing drawings for the TKM style track and associated posts. This permits a customer to manufacture the steel part of the system and then order a carriage from Jetline, knowing that, when the carriage is received, it will be fully compatible with the locally manufactured track.

The TKM track is designed to be fabricated from readily available rectangular section tubing and bar. The carriage travels on the bar sections which are welded to the rectangular tube. This style of track can be un-machined or machined.

The **TKM-U** un-machined version of the track is manufactured using cold rolled steel bar and rectangular tubing, the cold rolled bar provides the surface on which the carriage travels. Because the track is un-machined, there is a wide tolerance on the tracking accuracy.

The **TKM-M** track is manufactured in the same way as the un-machined version but uses hot rolled instead of cold rolled steel. The hot rolled steel is machined to form the surface on which the carriage rides. The track can be machined to a straightness of 0.015" (0.4 mm) per 10 ft (3 m) length.

Support Posts

These are available to support the track and are provided with track adjustment brackets at their upper end to correctly align the track. Two support posts are sufficient for all tracks up to 20 ft (6 m) long. The posts have floor pads with mounting holes and leveling bolts. Special height posts are available to order.

Carriages

The carriage which is used with the TKM style track is of formed construction with a large mounting face for the welding head. The carriage is available as a non-powered or a powered version. Powered versions are available with various speed ranges and speed holding accuracies and are rack and pinion driven. The full range is shown in the chart below. Load carrying capacity is 500 lb (225 kg) out 12" (300 mm) from the carriage face when used with either the un-machined TKM-U or the machined TKM-M track.

The carriage rides on the track using hardened cam followers which are sealed for life and which provide smooth travel.

Powered carriages are driven by a DC servomotor controlled by Jetline's unique 9627 microprocessor control. This control sets and maintains the carriage travel speed and can also be interfaced with a suitable welding power supply and with other Jetline microprocessor controls to provide complete sequence control of the weld process. The input voltage is 110/230VAC, 50/60 Hz.

Adding a tach-generator to the motor improves the speed holding accuracy of the standard carriages to a level better than $\pm 1\%$ of the rated speed.

Model	Speed Range		Accuracy
	IPM	mm/min	
SWC-9	Non-Powered		
SWCB-8A	3 - 135	75 - 3425	2%
SWCB-8B	2.2 - 105	55 - 2650	2%
SWCB-8C	1.2 - 55	30 - 1400	2%
SWCB-8D	0.8 - 37	20 - 940	2%

TKMV MEDIUM-DUTY VEE-WAY STYLE

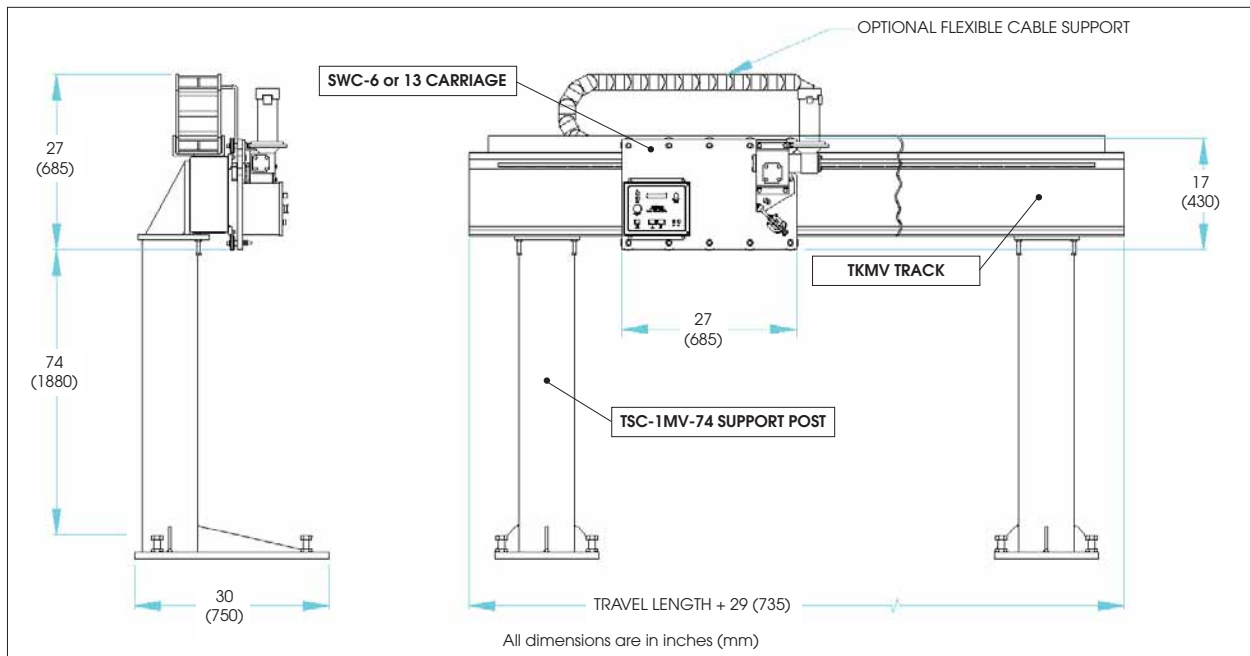

Track

The **TKMV** style track is fabricated from a thick wall, rectangular steel tube. Steel bars are welded to the tube and the complete track assembly is then stress relieved. After stress relieving the track is machined and hardened vee-ways are attached, these form the track on which the carriage rides.

A gear rack is mounted on a machined face on the track, the pinion gear on the carriage engages this rack to provide powered movement. Tracking accuracy is guaranteed to be better than $\pm 0.015"$ (0.4 mm) per 10ft (3 m) length.

The heavy duty nature of this track makes it suited to carry multiple carriages. It is ideal for applications where two circumferential welds are being carried out on a tank or vessel and there is a need to carry heavy welding heads, possibly with large wire reels for GMAW or submerged-arc welding.

This style of track has no length limitation, it can be manufactured for any desired weld length. Lengths over 40 ft (12 m) will be supplied in sections with a splice to join together the separate track lengths.

Support Posts

These are available to support the track and are provided with track adjustment brackets at their upper end to correctly align the track. Two support posts are used on tracks up to 20 ft (6 m) long, over this length, the support posts are set at 15 ft (4.6 m) spacing. The posts have floor pads with mounting holes and leveling bolts. Special height and powered elevation posts are available to order.

Carriages

The carriage which is used with the TKMV style track is manufactured from aluminum tooling plate to provide a large mounting face for the welding

head. The carriage is available as a non-powered or a powered version. Powered versions are available with various speed ranges and speed holding accuracies and are rack and pinion driven. The full range is shown in the chart below. Load carrying capacity is 1,000 lb (450 kg) out 12" (300 mm) from the carriage face.

The carriage rides on the track using two sets of hardened vee-way wheels, these are sealed for life and provide precise, smooth travel. Adjustment facilities are provided on the lower wheels, these can be adjusted to compensate for any wear in the track.

Powered carriages are driven by a DC servomotor controlled by Jetline's unique 9627 microprocessor control. This control sets and maintains the carriage travel speed and can also be interfaced with a suitable welding power supply and with other Jetline microprocessor controls to provide complete sequence control of the weld process. The input voltage is 110/230VAC, 50/60 Hz.

Adding a tach-generator to the motor improves the speed holding accuracy of the standard carriages to to a level better than $\pm 1%$ of the rated speed.

Model	Speed Range		Accuracy
	IPM	mm/min	
SWC-13	Non-Powered		
SWC-6A	4 - 165	100 - 4200	2%
SWC-6B	3 - 108	75 - 2750	2%
SWC-6C	2 - 67	50 - 1700	2%
SWC-6D	1 - 45	25 - 1150	2%

TKHV HEAVY-DUTY VEE-WAY STYLE

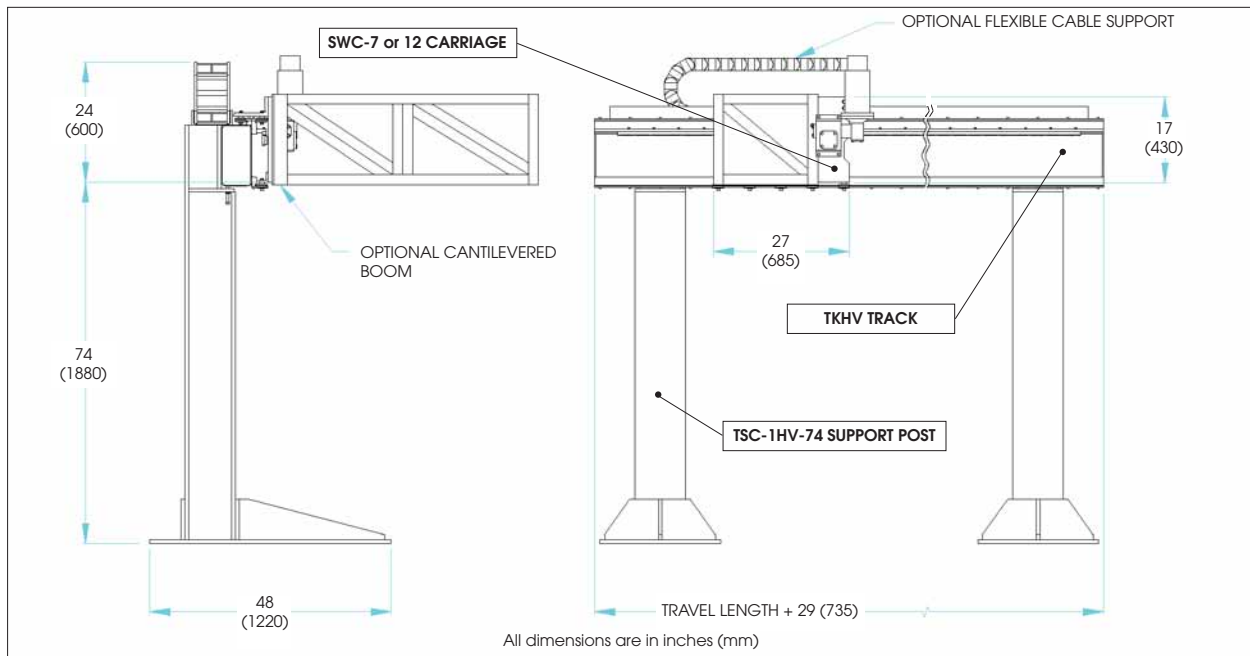

Track

The **TKHV** style track is fabricated from a very heavy wall, rectangular steel tube. Steel bars are welded to the tube and the complete track assembly is then stress relieved. After stress relieving the track is machined and hardened vee-ways are attached, these form the tracks on which the carriage rides.

A gear rack is mounted on a machined face on the track, the pinion gear on the carriage engages this rack to provide powered movement. Tracking accuracy is guaranteed to be better than $\pm 0.015"$ (0.4 mm) per 10 ft (3 m) length.

The heavy duty nature of this track makes it suited to carry multiple carriages and cantilevered booms. A range of booms is available, the booms can be fitted with tracks and carriages to provide in and out movement of the welding head, either manual or motorized.

This style of track has no length limitation, it can be manufactured for any desired weld length. Lengths over 40 ft (12 m) will be supplied in sections with a splice to join together the separate track lengths.

Support Posts

These are available to support the track and are provided with track adjustment brackets at their upper end to correctly align the track. Two support posts are used on tracks up to 20 ft (6 m) long, over this length, the support posts are set at 15 ft (4.6 m) spacing. The posts have floor pads with mounting holes and leveling bolts. Special height and powered elevation posts are available to order.

Carriages

The carriage which is used with the TKHV style track is manufactured from aluminum tooling plate to provide a large mounting face for the welding

head. The carriage is available as a non-powered or a powered version. Powered versions are available with various speed ranges and speed holding accuracies and are rack and pinion driven. The full range is shown in the chart below. Load carrying capacity is 1,500 lb (680 kg) out 12" (300 mm) from the carriage face and 200 lb (90 kg) out 120" (3 m) from the carriage face.

The carriage rides on the track using three sets of hardened vee-way wheels, these are sealed for life and provide precise, smooth travel. The orientation of the wheels makes this carriage ideal for the support of cantilevered loads.

Powered carriages are driven by a DC servomotor controlled by Jetline's unique 9627 microprocessor control. This control sets and maintains the carriage travel speed and can also be interfaced with a suitable welding power supply and with other Jetline microprocessor controls to provide complete sequence control of the weld process. The input voltage is 110/230VAC, 50/60 Hz.

Adding a tach-generator to the motor improves the speed holding accuracy of the standard carriages to better than $\pm 1%$ of the rated speed.

Model	Speed Range		Accuracy
	IPM	mm/min	
SWC-12	Non-Powered		
SWC-7A	4 - 165	100 - 4200	2%
SWC-7B	3 - 108	75 - 2750	2%
SWC-7C	2 - 67	50 - 1700	2%
SWC-7D	1 - 45	25 - 1150	2%

OPTIONAL ITEMS AND ACCESSORIES

Flexible Cable Carrier

Any track can be fitted with a flexible cable carrier to carry all the supply hoses and cables.

Mounting Brackets

A complete range of brackets to mount the welding head to the carriage is available. The brackets are fitted with cross slides to adjust the torch position relative to the weld joint, these include X, X-Y, X-Y-Z and combinations with rotation and tilt facilities.



Cold and Hot Wire Feeders

A full range of wire feeders, both for cold and hot wire feeding, are available. Wire sizes from 0.020 to 3/32" (0.5 to 2.4 mm) can be accommodated. Models include both two and four drive roll varieties.



9500 System Controller

The 9500 System Controller is a microprocessor-based system capable of simultaneously controlling four welding parameters. The unit has closed loop control capabilities, this provides parameter accuracy levels better than $\pm 1\%$ of the set level.

The 9500 can be used for the control of any arc welding process and will store up to 25 weld programs in its memory. Additional program storage is available through the use of the optionally available memory pendant and memory cards.

The unit can be set to control multi-pass welding and can be programmed to control up to 25 sequential weld passes, each pass can use entirely different parameters.

Ease of use is assured by the custom designed menu-driven software.

Welding Gear

Jetline can interface the welding power supply and other welding gear with any track and carriage to provide a completely integrated welding system. Equipment for any welding process can be fitted including GTA, Plasma, GMA and submerged arc. All necessary cables and hoses will be supplied to provide a system which can be introduced into production immediately following delivery.



Seamtrackers

Jetline manufactures and supplies a full range of equipment for the tracking of the weld joint.

The microprocessor-based tactile seam tracker uses the latest control technology to assure consistent, accurate tracking of the weld seam. This is achieved by the use of a tactile probe which senses the position of the seam relative to the welding head. A signal is sent through the control to the cross-slide motors which drive the slides up or down and left or right to maintain the correct welding torch position.

For applications where it is not possible to use a tactile probe, the optical seam tracking system is available. This system uses a sensor which "paints" the part with a laser stripe. The resulting image is received, analyzed, and corrective signals sent to the cross slides.

A large range of cross-slides with different weight capacities and stroke lengths is available from Jetline for virtually any welding application.

Arc Length Control

Jetline's Model 401 microprocessor-controlled arc length control is used for GTAW (TIG) and Plasma (PAW) welding. It is designed to maintain a precise and consistent arc length throughout the weld process. The unit includes a touch retract facility to preset the arc length prior to welding.

The microprocessor design provides easy-to-use setup screens and an uncluttered front panel for operator convenience. The menu-driven software provides ease of use.

Two arc length control actuators are available, one with 6" (150 mm) stroke, the other with 12" (300 mm) stroke. This extended stroke is ideal for circumferential applications to accommodate different part diameters.

See Jetline price list for complete ordering information

Distributed by:

Jetline
engineering
An Illinois Tool Works Company

15 Goodyear St., Irvine, California 92618 USA
Tel: (949) 951-1515 • Fax: (949) 951-9237 • E-mail: sales@jetline.com

Web Page: www.jetline.com • www.cyclomatic.com